

10. HELPFUL INFORMATIC

- 1) Always keep the sealing platform clean. Particular care "should" be taken to remove any residue from the Teflon tape.
- 2) Do not clean the sealing platform with anything wet.
- 3) Make sure to change the upper Teflon tape (above the element wire) and the lower Teflon strip (below the element wire) when they become worn. If this is not done the element wire may short out and become damaged.
- 4) When replacing the heating element always check the condition of the bottom Teflon tape. It is important that you replace the element wire only with the one made for this machine. You can damage the transformer with the wrong element wire.
- 5) Occasionally check the condition of the top pressure pad (silicon rubber) for wear or burn. A poor rubber pad will effect on the quality of your seal.
- 6) USE ONLY GENUINE REPLACEMENT PARTS

IMLULSE FOOT SEALERS WITH CUTTER

450FC, 455FC, 600FC, 605FC

INSTRUCTION

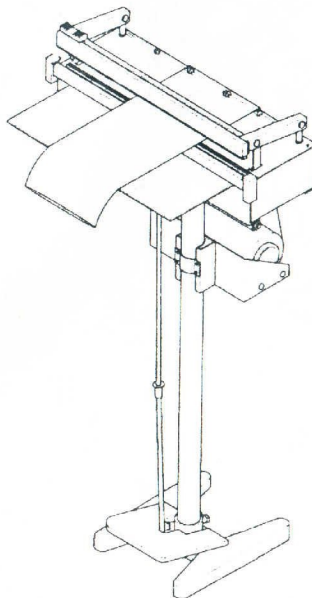

1. CONSTRUCTION DIAGRAM

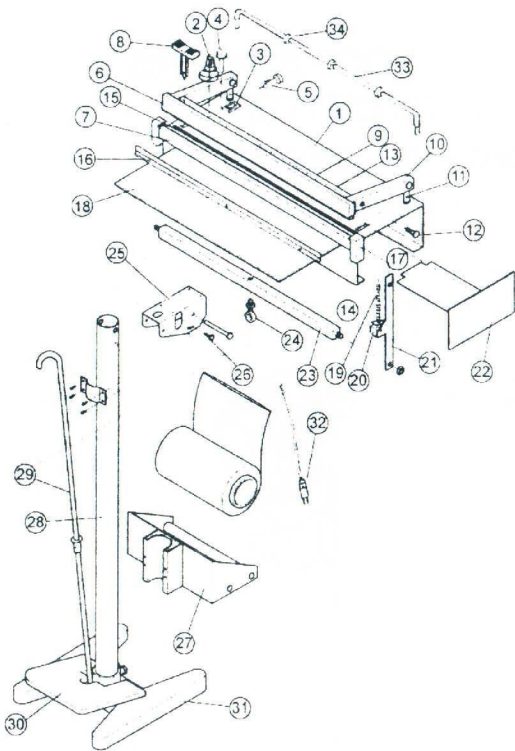

2. PARTS LIST

- | | |
|------------------------------|------------------------|
| 1) Enclosure Body | 18) Working Plate |
| 2) Timer Control Knob | 19) Return Spring |
| 3) Power Main Switch | 20) Limited Switch |
| 4) Sealing Indication Lamp | 21) Pull Sealing Lever |
| 5) Fuse Holder | 22) End Cover Plate |
| 6) Upper Sealing Jaw | 23) Lever Bar |
| 7) Lower Sealing Jaw | 24) Pull Screw |
| 8) Cutting blade | 25) Enclosure Bracket |
| 9) Holder Plate for Cutter | 26) Angle Fixed Screw |
| 10) Lever Frame | 27) Roll Bracket |
| 11) Connect Poles | 28) Standing Tube |
| 12) Bolt Pin | 29) Dower Lever Rod |
| 13) Rubber Pad for Cutting | 30) Pedal |
| 14) Sealing Silicon Rubber | 31) Pedal Base |
| 15) Clip for Teflon Cloth | 32) Power Plug |
| 16) Fixed Plate of Cloth | 33) Bag press Bar |
| 17) Heater Terminal Assembly | 34) Bag Fixed Ring |

3. OPERATING INSTRUCTIONS

1. Connect power supply plug to AC outlet.
2. Put the plastic bag on the roll bracket then will it through between the sealing jaws.
3. Turn on Main Switch. Yellow light appears, indicating power to the unit.
4. Adjust the timing knob to the lower number and STEP ON the pedal about one second after the red lamp gone out automatically while you press the pedal, this is the cooling time.
5. Slide the cutter to cut the plastic bag.
6. The jaws will open when cycle is completed and you can remove the package bag and begin the cycle anew.

4. ASSEMBLING FOR FOOT SEALER

- 1) Insert standing tube into pedal base and fixed with two short screws.
- 2) With long screw connect standing tube and bracket of enclosure body, then adjust need angle use the two 6mm screw fixed.
- 3) Attach puller rod form hooked puller (pull screw located under bracket) and then attach to foot pedal.
- 4) Fixed the bag roll bracket to the standing tube.
- 5) Connect working plate fixed to from enclosure body, located at lower Teflon Fixed Plate

5. CAUTIONARY MARKING

CAUTION:

- 1) To reduce the risk of shock, disconnect the unit from the supply circuit before servicing the replacement of the heating element.
- 2) To provide continued protection against risk of electric shock, connect to properly grounded outlet only.

WARNING:

- 1) A live heating element is located in the jaw under the Teflon tape. Use caution during operation. **DO NOT TOUCH THE ELEMENT.**
- 2) For Continued Protection Against Fire or Electric shock, Replace Only With Type Cartridge and 10 Ampere Fuse, provided in legible adjacent to fuse holder.
- 3) If the supply cord is damaged, it must be replaced by a special cord or assemble available from the manufacturer or its service agent.

6. ELECTRIC CONNECTION DIAGRAM

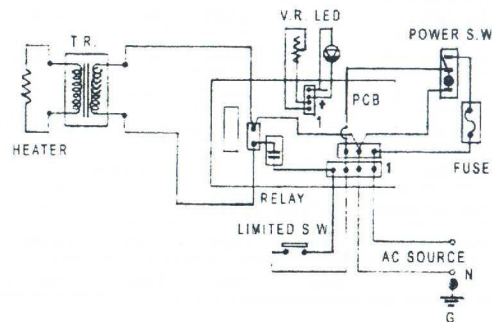

7. CHANGING PARTS

To replace burnt out Teflon tape or broken element wire please follow these instruction:

REMOVE PLUG FROM ELECTRIC OUTLET
USE ONLY GENUINE REPLACEMENT PARTS

- 1) To replace Teflon
 - a. Remove low Teflon fixed plate. Loosen Teflon clips.
 - b. Pull out Teflon tape just enough to cut off burned area. Smooth out Teflon and re-fix the Teflon fixed plate.
 - c. Rotate Teflon screw to pull Teflon tight. Retighten the Teflon clips.
- 2) Replacing heating element wire
 - a. Loosen Teflon clips. Remove the low Teflon fixed plate.
 - b. Lift up Teflon and remove broken element wire from heater poles. (Heater Element Attachment).
 - c. Put new element wire on heater poles. Do not bend or crimp the wire.
 - d. Replace Teflon and Teflon fixed plate. Tighten Teflon with Teflon screw. Tighten Teflon clips.

8. SPECIFICATIONS

MODEL	450FC	455FC	600FC	605FC
Max. Seal Length	450mm (18")	450mm (18")	600mm (24")	600mm (24")
Seal Width	2mm	5mm	2mm	5mm
MAX. Cutting Length	400mm (16")	400mm (16")	600mm (22")	600mm (22")
Heat Time	0.2-2.0sec	0.2-2.0sec	0.2-2.0sec	0.2-2.0sec
Max. Seal Thickness	2x0.15mm	2x0.15mm	2x0.15mm	2x0.15mm
Watts	600W	1200W	800W	1500W
Weight	24kg	26kg	28kg	30K

9. SPARE PARTS

ACCESSORIES	Q'TY
Cutting Blade	1
Heating wire	2
Fuse	10Ax1 or 20Ax1

No.	Description	Part Number
1	ENCLOSURE BODY	*BODY-FC
2	TIMER CONTROL KNOB	*KNOB
3	POWER MAIN SWITCH	*ROCKSW
4	SEALING INDICATION LAMP	
5	FUSE HOLDER	*FUSEBOXF
6	UPPER SEALING JAW	*UPJAW-FC
7	LOWER SEALING JAW	*LJAW-FC
8	CUTTING BLADE	*BHOLD-FC
9	HOLDER PLATE FOR CUTTER	*455FC#9
10	LEVER FRAME	*455FC#10
11	CONNECT POLES	*455FC#11
12	BOLT PIN	*455FC#12
13	RUBBER PAD FOR CUTTING	*455FC#13
14	SEALING SILICON RUBBER	*SR455FC
15	CLIP FOR TEFLONE RUBBER	*455FC#15
16	FIXED PLATE OF CLOTH	*455FC#16
17	HEATER TERMINAL ASEMBLY	*CAPSETFI
18	WORKING PLATE	*TA450FL
19	RETURN SPRING	*FC#19
20	LIMITED SWITCH	*MICRO-FI
21	PULL SEALING LEVER	*455FC#21
22	END COVER PLATE	*455FC#22
23	LEVER BAR	*455FC#23
24	PULL SCREW	*FC#24
25	ENCLOSURE BRACKET	*455FC#25
26	ANGLE FIXED SCREW	*455FC#26
27	ROLL BRACKET	*455FC#27
28	STANDING TUBE	*STAND-FC
29	DOWER LEVER ROD	*ROD
30	PEDAL	*PEDAL
31	PEDAL BASC	*BASE
32	POWER PLUG	*CORD
33	BAG PRESS BAR	
34	BAG FIXED RING	*455FC#34